



13046 Race Track Rd. #187
Tampa, FL 33626
(813) 463-2420
www.eag-led.com

WALL PACK LIGHT



Advantages

- UL cUL DLC certificate
- IP65 driver, Input voltage 100-277Vac
- No UV or IR in the beam
- No Maintenance
- No UV or IR in the beam
- Energy efficient, long lifespan
- Instant start, NO humming
- Green and eco-friendly without mercury.

Applications

- Entrance lighting, Wall lighting
- Landscaping lighting, Hotels



13046 Race Track Rd. #187
 Tampa, FL 33626
 (813) 463-2420
 www.eag-led.com

WALL PACK LIGHT

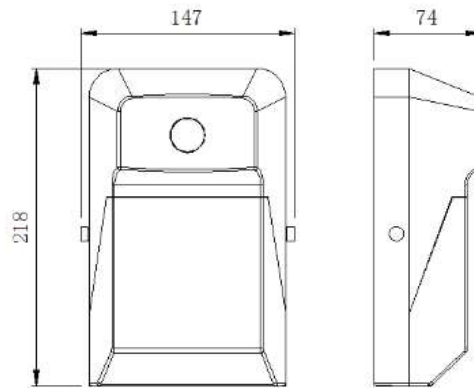

Technical Specifications

Color Temperature	3000 – 5700K	Waterproof Rating	IP65
CRI	>80	Operating Temperature	-20°C TO 45°C
Lumen	1575– 1720LM	Operating Humidity	20% - 90% RH
Input Power	15W	Storage Temperature	-30°C TO 80°C
Viewing Angle	110 degree	Storage Humidity	10% - 95% RH
Input Voltage	50-60 HZ	Application	Indoor/Outdoor
PFC	>.9	Certification	UL cUL DLC
Housing color	Black	Housing	Aluminum

Product Specifications		Materials	
Product Name	LED Wall Pack Light	Driver Model	China Brand Driver
Part Number	EAG-WP2-15W	LED Type	2835 .2W
Dimension	218*147*74mm	Optional Accessory	Photocell option



13046 Race Track Rd. #187
 Tampa, FL 33626
 (813) 463-2420
 www.eag-led.com

WALL PACK LIGHT

Testing Parameters

DATA OF LAMP		PHOTOMETRIC	DATA Eff: 105.30 lm/W
MODEL		Imax(cd)	660.461
NOMINAL POWER(W)	15	LOR(%)	100.0
RATED VOLTAGE(V)	277	TOTAL FLUX(lm)	1605.8
NOMINAL FLUX(lm)	1605.80	CIE CLASS	DIRECT
LAMPS INSIDE	1	D up(%)	9.5
TEST VOLTAGE(V)	277	down(%)	90.5

