



13046 Race Track Rd. #187
Tampa, FL 33626
(813) 463-2420
www.eag-led.com

HIGH BAY LIGHT



Advantages

- UL cUL DLC certificate
- High CRI
- IP65 driver, Input voltage 100-277Vac
- No UV or IR in the beam
- Easy to install and operate
- Light is soft and uniform, Safe to eyes
- Energy saving, Long lifespan
- Instant start, NO flickering, NO humming
- Green and eco-friendly without mercury.
- Fully dimmable, motion sensor capabilities

Applications

- Warehouse, factory, workshop
- Gas stations, toll station
- Gymnasium



13046 Race Track Rd. #187
 Tampa, FL 33626
 (813) 463-2420
 www.eag-led.com

HIGH BAY LIGHT

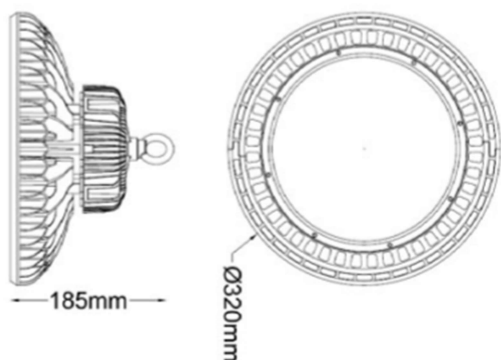

Option 1

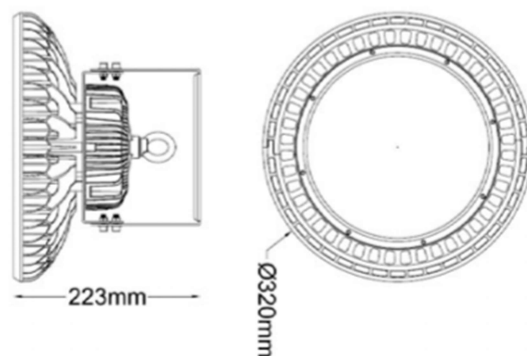

Option 2

Technical Specifications

Color Temperature	4000 – 5700K
CRI	>80
Lumen	14000LM
Input Power	100W
Viewing Angle	120 Degree
Input Voltage	50-60 HZ
Waterproof Rating	IP65
PFC	>.9

Operating Hours	50,000
Operating Temperature	-20°C TO 40°C
Operating Humidity	20% - 90% RH
Storage Temperature	-30°C TO 80°C
Storage Humidity	10% - 95% RH
Application	Outdoor/Indoor
Certification	UL cUL DLC
Housing	Aluminum

Product Specifications	
Product Name	LED High Bay Light
Part Number	EAG-HB2-100W
Dimension	1: 320*185mm 2: 320*223mm

Materials	
LED Brand	Phillips Lumileds
LED Type	Luxeon 3030 2D (1.5W)
Driver	HBG-100-60B (Mean Well)