



13046 RACETRACK RD SUITE 187 TAMPA FL 33626 813-463-2420

EAG-LED WALL PACK LIGHT

EAG-WP-150W



Advantages

- UL DLC certificate
- High CRI
- Input voltage 100-277VAC
- No UV or IR in the beam
- Easy to install and operate
- Energy saving, long lifespan
- Light is soft and uniform, safe to eyes
- Instant start, NO flickering, NO humming
- Green and eco-friendly without mercury.

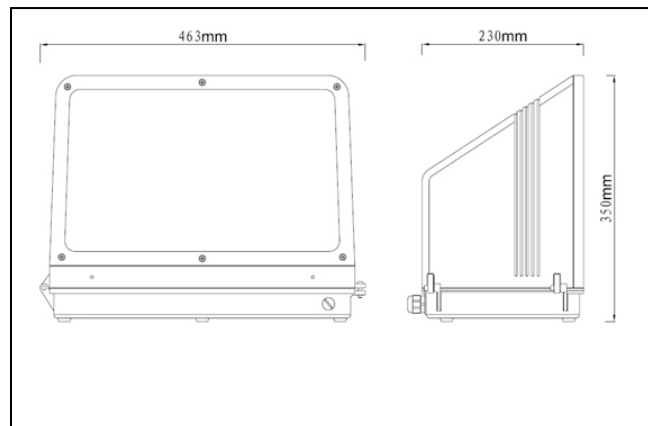

WWW.EAG-LED.COM



13046 RACETRACK RD SUITE 187 TAMPA FL 33626 813-463-2420

EAG-WP-150W Technical data

Product name	LED WALL PACK Light
Color Temperature	4000-5700K
CRI	>80Ra
Lumen	13500-15000LM
Input Power	150W
Viewing Angle	120 Degree
Input Voltage	AC100-277V
Frequency Range	50-60 HZ
PFC	>90%
Waterproof Rating	IP65
Operating Temperature	-20°C TO 45 °C
Operating Humidity	20%-90% RH
Storage Temperature	-30°C TO 80 °C
Storage Humidity	10%-95% RH
Application	Outdoor
Certification	UL DLC CE RoHS
LED Type	2835, 0.5W
LED QTY	390PCS
Housing	Aluminum(ADC12)+Stalinite
Housing Color	Black

WWW.EAG-LED.COM



13046 RACETRACK RD SUITE 187 TAMPA FL 33626 813-463-2420

Light Distribution Diagram

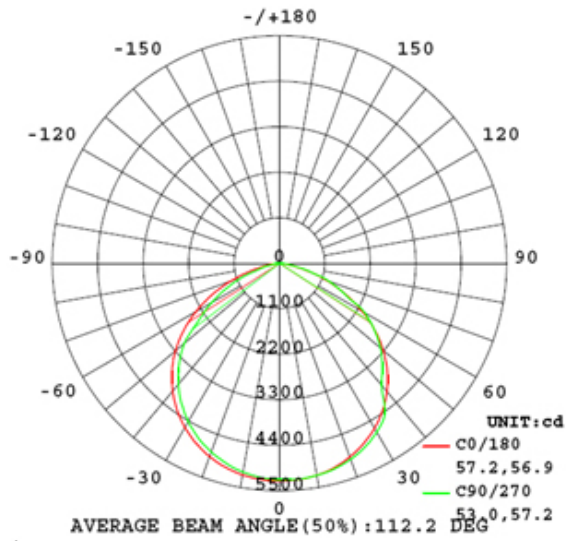

Flux out: 11125 lm

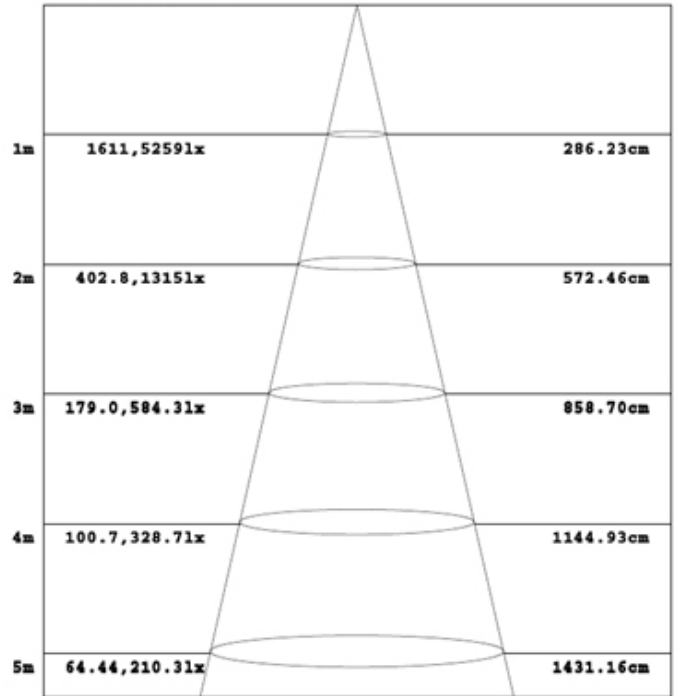

Note: The Curves indicate the illuminated area and the average illumination when the luminaire is at different distance.



13046 RACETRACK RD SUITE 187 TAMPA FL 33626 813-463-2420

Applications

- Lighting Factories
- Outdoor Landscape Lighting
- Buildings, Hotels, or as Lighting for Building Exterior.

